

Conveying Unit R 320-38

Pneumatic conveying systems

**Rust-free
construction**

Compact design

Low in height

Easy to clean

Preferred applications

The conveying unit type R 320-38 serves for reliable feeding of free-flowing powders or granular bulk materials into processing machines. It is particularly useful for transferring pellets, regrind or masterbatch to injection moulding machines, extruders or blow-moulding machines etc. In the food industry it is used for conveying pulses, rice etc. The materials can be picked up from e.g. sacks, drums, containers or silos.

Special advantages

- Stainless steel body
- Compact design with a sturdy ring blower, suitable for continuous operation
- Large filter with compressed air purging
- No interruption of output due to a device indicating that the supply of material at the pick-up point is running low
- High functional reliability through electronic control and monitoring

DIE INNOVATION

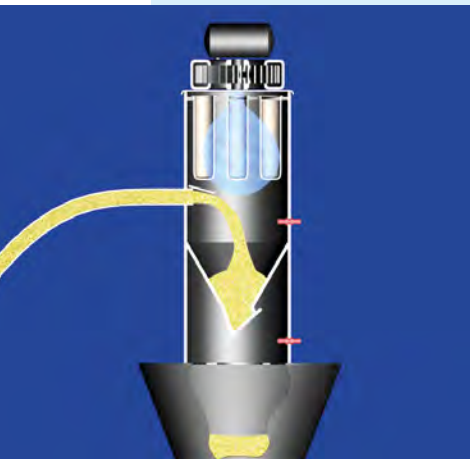

How it works

Product is conveyed discontinuously. After plugging in the safety plug and actuating the toggle switch, the green light goes on and the unit is ready for operation. The blower then produces a vacuum in the receiver causing the material to be drawn into the conveying unit via the suction nozzle and the conveying line. This process is indicated by a yellow light. When the conveying

phase is over, the discharge valve opens and the material flows out. As soon as the automatic level control requests more material, a new conveying cycle is initiated. After each conveying phase, the filter is automatically purged by compressed air pulses and the air escapes via the vent filter. If there is no more product at the pick-up point or a problem with the unit, a red light goes on at the control.

Design

The compact design and the high-grade stainless steel body are outstanding features of this conveying unit. Snap-on locks permit simple and fast cleaning without tools. The blower is protected by a large filter which is purged by means of compressed air after each conveying cycle. The electronic control system is housed in a plastic box at the unit ready for operation. It controls the conveying operation and indicates when there is no more product at the pick-up point. The discharge valve also acts as an automatic request indicator. An inspection port with a vent filter is provided in the lower section of the unit. The unit is mounted on the customer's machine hopper by means of a clamping ring with a snap-on lock which also permits quick dismounting for cleaning.

Technical data

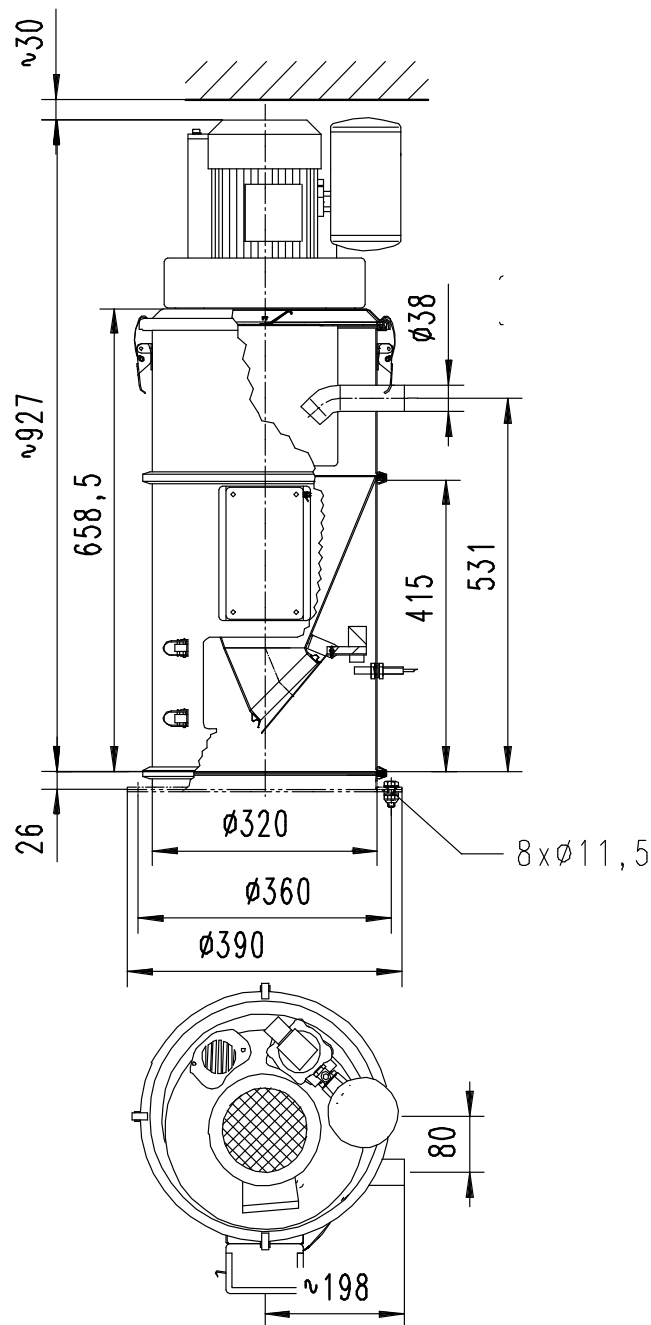

Designation: R 320-38
 Capacity: 12 litres
 Net weight: 35 kg
 Filter area: 2 x 0.25 m²
 Compressed air: Free of water and oil

Permissible pressure: 4 bar
 Conveying time: Adjustable
 10 – 60 sec
 Pause time: 10 - 120 sec.
 Drive: 1.1 kW, 230 V
 50 Hz
 Sound level: 69 dB (A)
 Max. ambient temperature: 50° C

ATEX:

The conveying unit **must not be operated** in gas or dust explosive atmospheres.